



# QBIC Activity Tracker

The Q-Belt Integrated Computer (QBIC) is a wearable computer with enough computational power to support a wide range of applications. The system is batch produced by ETH Zurich as a research platform to collect and compute information for context recognition projects. Various applications are supported such as monitoring activities of daily living, tracking location or monitoring of user actions in work process flows, to name a few.



## Design for Wearability

No need to say that the QBIC is designed for wearing, it is optimised to be comfortable without compromising its reliability.

The buckle contains two circuit boards, the main board with the CPU, SDRAM and power supply and an extension board with the Bluetooth device, the USB host controller and the MMC slot. It can be taken off the belt to operate at a development board.

The belt contains a battery, an additional battery can be attached externally, USB ports, Serial ports (RS232) and the VGA connector.

Since the QBIC runs Linux (TM), it is ideally suited to power complex communication and data processing applications.



## QBIC Activity Tracker

By its concept, the QBIC lends itself ideally as long-term monitoring system. We test-drive it for the recording of daily activities recording acceleration of different body parts and other sensors.

## QBIC version 2.0

New belt design.  
New black buckle.  
New Bluetooth module.  
New Linux distribution.

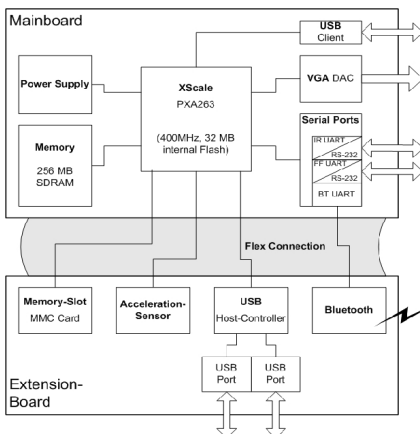

## System Architecture

CPU: XScale, 400MHz.  
Flash: 32 MB.  
RAM: 256MB.  
MMC slot.  
USB host ports.  
Serial connectors.  
VGA plug.  
Bluetooth.  
Belt integrated battery.  
External battery (hot-swappable).

